

Stability of EUV multilayers to long-term heating, and to energetic protons and neutrons, for extreme solar missions

A.D. Rousseau^a, D.L. Windt^b, B. Winter^a, L. Harra^a, H. Lamoureux^a, and F. Eriksson^b

^a University College London – Mullard Space Science Laboratory, Holmbury House, Holmbury St Mary, Dorking, Surrey, RH5 6NT, UK

^b Columbia Astrophysics Laboratory, 550 West 120th St, New York, NY 10027

1. ABSTRACT

We have systematically investigated the thermal and particle stability of several state-of-the-art EUV multilayer coatings suitable for use in high-performance solar instrumentation. Our research has been motivated principally by the performance requirements for extreme solar missions such as Solar Orbiter, an approved ESA mission with an expected launch date of 2013. The goal of this particular mission is to explore the solar atmosphere with both in situ and remote sensing instrumentation at a close encounter. At perihelion the mission will reach 0.2 A.U. providing a unique viewpoint where the instruments can both ‘see’ and ‘feel’ the dynamic atmosphere. But the orbit is technically challenging—no remote sensing instrument has been put in such close proximity to the Sun before. Furthermore, the thermal and particle environment will not only be severe but will suffer huge fluctuations as the elliptical orbit changes from 0.2 A.U. to 1.1 A.U. Several of the remote sensing packages on the strawman payload of the mission contain multilayer coatings, thus the stability of these coatings to the expected thermal and particle environment must be established. In this paper, we investigate the impact on the integrity of several candidate EUV multilayer coatings after long-term thermal annealing, and upon exposure to energetic protons and neutrons. In summary, we find no significant degradation in any of the multilayer samples tested. These results suggest that the multilayers we have studied can be safely used for Solar Orbiter or other extreme solar missions.

Keywords: Multilayer, EUV reflectance, X-ray reflectance, Proton irradiation, Neutron irradiation, Thermal anneal, Solar Orbiter

2. INTRODUCTION

The Solar Orbiter (SO) mission represents a completely new approach to studying the Sun and will transform our knowledge of our nearest star. The mission has three unique perspectives to it, which are described by Colangelo et al. (2000). In summary they are:

- (a) **Close approach:** this is the closest approach ever to have been made and will reach as close as 0.2 A.U. (45 solar radii). There will be a combination of remote sensing and in situ instruments on board which will provide high resolution imaging of the solar atmosphere to look at the dynamics of the atmosphere combined with in situ measurements of particles and waves that are leaving the Sun and stream past the spacecraft. Currently we are observing dynamical behaviour 1 A.U. away and cannot directly measure the flow of material until it has travelled 1 A.U. from the Sun.
- (b) **Sun-synchronous rotation:** the orbit has been determined in order that the speed of the spacecraft close to perihelion matches that of solar rotation. This means that the difficulties of linking the complex phenomena on the Sun to the particles streaming past the instruments will be less complex than it currently is. We can only attempt to connect events on the Sun that are at limited locations on the disk.
- (c) **Out of ecliptic measurements:** the inclination of the orbit will increase each orbit using swing-by manoeuvres at Venus along with Solar Electric Propulsion (SEP). This will allow the orbit to reach 38 degrees out of the ecliptic. Since the source of the fast solar wind is mostly at the poles of the Sun, this will allow us to probe the source of this fast stream wind using for the first time imaging and spectroscopic observation alongside in situ measurements.

A complex orbit is required in order to achieve the objectives just outlined; this orbit, with its thermal and particle fluctuations, will strain the remote sensing packages in particular. Figure 1 illustrates the SO orbit related to the Earth and Venus's orbits. The 3 conditions that produce the largest challenges for the design of the remote sensing spacecraft are the following;

- (a) The mass is constrained: due to the complex orbit with the requirement of Solar Electric Propulsion (SEP), and the launcher that will be used (the Soyuz-Fregat) there are huge constraints on mass. The current mass available for the EUV imaging package, which includes 3 high-resolution telescopes and one full Sun imager, is approximately 20 kg. This is a factor of 3 smaller than one full Sun telescope in Earth orbit such as the EUV imaging telescope on SOHO, and yet there will be 4 telescopes in total in this package. The length of the remote sensing instruments is limited to 1 m in length.
- (b) The particle environment will be more severe. The background solar wind proton flux will be approximately 25 times that of, for example, an Earth orbiting mission at perihelion. There will be an increased chance of encountering proton storms from coronal mass ejections as well. There will also be occasional impacts from solar flare neutrons. Because of these reasons standard CCD detectors are not baselined for the mission – APS detectors are planned instead.
- (c) The thermal environment will be extreme. Due to the close encounter there will be huge changes in the temperature of the spacecraft. This is controlled to some extent by the use of a sunshield. The temperature at perihelion of the instruments would otherwise reach 400 C. Other methods are being used such as reducing the aperture of the remote sensing instruments.

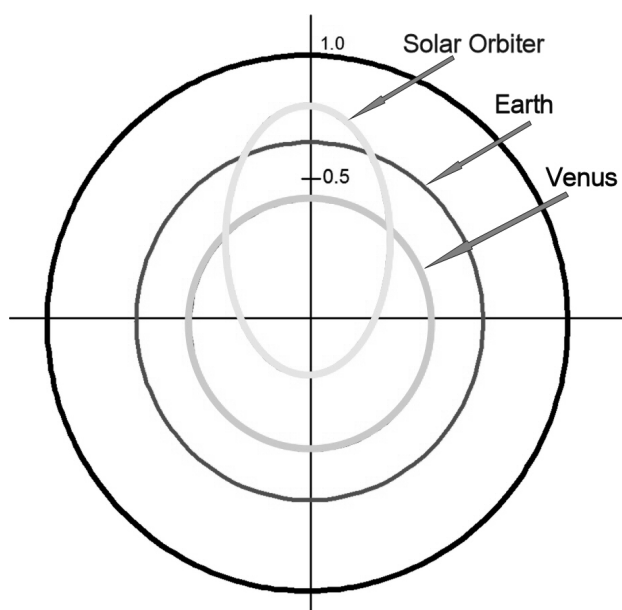

Figure 1 Orbit of SOLAR ORBITER in relation to the orbits of the Earth and Venus.

In this paper we consider specifically the high-resolution imager that we are developing. Our results, however, should apply as well to any instrument utilizing multilayer coatings. The design is based on the Multi-order Solar EUV spectrograph (MOSES), which will be launched in August 2005 as a proof of concept. (5, 6) Both the primary mirror and the gratings are coated with narrowband EUV multilayers.

3. EXPERIMENTAL PROCEDURE

In order to assess the stability of EUV multilayers in support of extreme solar missions such as Solar Orbiter, we have systematically exposed several candidate multilayer coatings to long-term heating and to energetic particles, and have

compared the structure and performance of the exposed coatings with identical coatings kept as control samples. While a number of previous studies have investigated the effects of multilayer thermal annealing at elevated temperatures for relatively short periods of time (minutes to hours), to our knowledge there are no comprehensive, systematic measurements of the effects of long-term heating, or to particle exposure.

Multilayer coatings were deposited onto polished Si (100) wafers cleaved into 16x16mm sections, using a planar magnetron system that has been described previously. (1) This system has been used to coat the Solar-B/EIS optics (2), and will be used to coat some of the SDO/AIA telescope mirrors as well. (3) In this system the substrate faces down and rotates over the 9 cm x 50 cm rectangular magnetron cathodes, which face up, building up the multilayer one layer per pass. Individual layer thicknesses are controlled precisely by adjusting the substrate rotational velocity. The system is cryopumped, and all samples studied here were deposited with a background pressure of less than 3×10^{-7} Torr. The sputter gas (Ar) pressure was maintained at 1.6 mTorr. With cathode powers of several hundred watts, deposition rates are in the range 0.8 – 1.2 nm/s, depending on the material.

Materials	Period, d [nm]	Fractional Layer Thickness	Number of bilayers, N	Total thickness [nm]
Mo/Y	4.91	0.35	120	589
Si/Mo	10.55	0.6	20	211
SiC/Si	16.88	0.35	30	506
SiC/Mg	15.18	0.22	40	607

Table 1 EUV Multilayer Design Parameters

For this investigation we selected a variety of high-performance normal incidence multilayers spanning a wide range of EUV wavelengths, as listed in Table 1: Mo/Y designed for narrow-band response near 9.4nm wavelength; Si/Mo designed for broadband response near 20 nm; SiC/Si designed for narrow-band response near 30 nm; and SiC/Mg also designed for narrow-band response near 30 nm. The Mo/Y, SiC/Si and SiC/Mg films studied here were developed for the SDO/AIA instrument, while the Si/Mo coatings were developed for Solar-B/EIS.

The films were characterized using both normal incidence EUV, and grazing incidence X-ray reflectometry. The absolute 'at-wavelength' EUV reflectance was measured using a system described previously (1) comprising a laser-produced plasma EUV source, a varied-line-space grating monochromator, and a precision UHV goniometer. The 1x4mm monochromatic pencil-beam of EUV radiation was incident at 5 deg from normal, and the reflected intensity measured (with an avalanche photodiode) as a function of wavelength by scanning the grating. The absolute reflectance was computed as the reflected intensity divided by the incident intensity, which was also measured as a function of wavelength with the same detector, and with the sample positioned out of the beam. Any potential variation in reflectance across the surface of a sample could be identified by scanning the sample relative to the beam.

X-ray reflectance measurements, used to identify any possible microstructural changes in the films, were made using a sealed-tube X-ray source with a Cu anode, a germanium crystal monochromator tuned to the Cu $K\alpha$ line (8 keV), and a precision goniometer. Measurements were made in the θ - 2θ geometry, over a wide range of graze angles corresponding to nearly 7 decades of intensity variations.

4. TEST PHILOSOPHY

The purpose of the tests was to subject four different types of multilayer samples to thermal annealing and intense proton and neutron radiation and to assess whether this would result in coating damage and changes in reflectance. Reference samples were used to track the changes if they would occur. In the following figure the test flow is depicted.

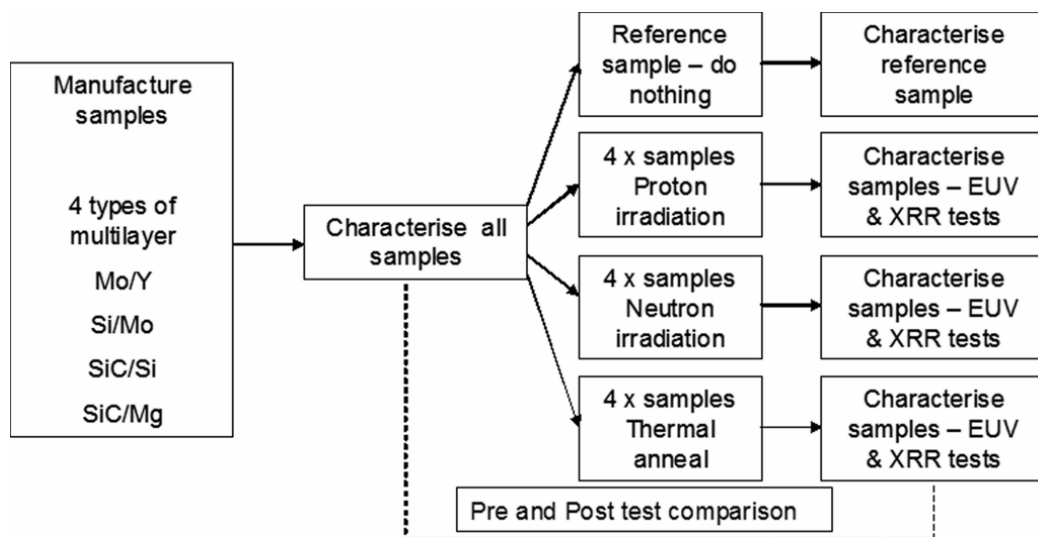

Figure 2 Test flow of the multilayer samples

Effectively four batches of test samples were produced of the four different types of multilayers. Three samples of each type were subjected to the various tests and a fourth sample was kept to have a reference. The reference was used to track changes due to ageing. All samples were characterised before and after the test campaign. Measurements were then compared to see if there had been changes.

5. THERMAL ANNEALING

The Solar Orbiter spacecraft will orbit the Sun at close range but in a highly elliptical orbit, ranging from 0.222 to 0.9 AU, with a corresponding heat flux varying between 1.7 and 27.8 kW/ m². The estimated thermal environment of this mission was used to define the multilayer thermal annealing experiments reported on here.

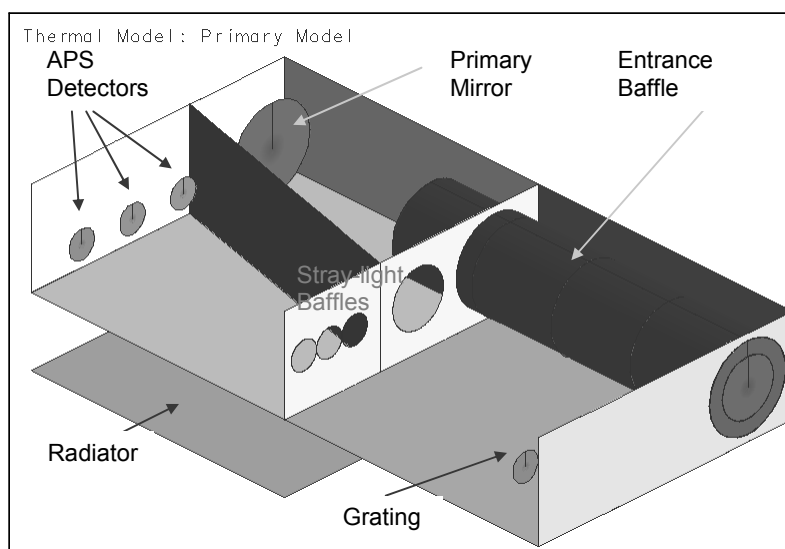

Figure 3 Main telescope parts that were used in the radiative-thermal model (side and top panels removed)

The simplified thermal model shown in figure 3 was used to estimate hot-case operating temperatures for the various parts. Table 2 shows the bulk properties that were used in the model. The telescope is looking through a hole in the spacecraft heat shield and is located inside the payload module (PLM). The thermal model boundary conditions were +20°C inside the PLM looking through a hole in the heat shield and receiving 27.8 kW/m² on its entrance filter.

Bulk label	kg/m ³	J/kg-K	W/m-K
CFRP	1800	840.0	1.8
Aluminium Bulk	2710	990.0	180.0
Copper Bulk	8900	385.0	390.0
Titanium	4430	523.0	7.4

Table 2: Bulk properties for basic materials used in the model (between 0 and 60°C)

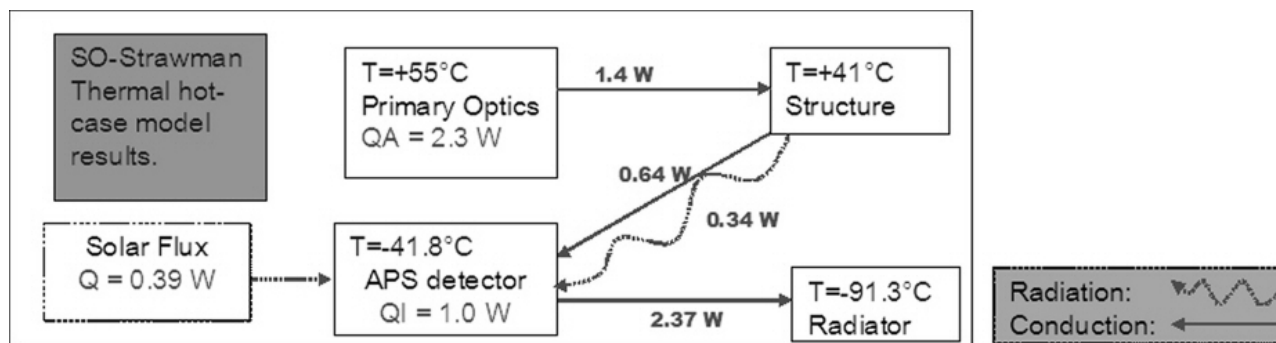

Figure 4 Solar Orbiter simplified thermal model results for structure, primary optics and detectors

The predicted optics temperatures (see figure 4) were used to define the annealing temperature of the multilayer samples studied here. The complete model (including heat shield and PLM) consists of 40 nodes, and the geometry with radiation coupling was taken into account. The annealing temperature for the multilayer test samples was set at +75°C (including a 20°C margin). In this study 1000 h annealing (at 75°C) was performed, representing roughly 2 orbits.

The thermal annealing system at UCL Mullard Space Science Laboratory consisted of a stainless steel vacuum chamber with a controlled heater jacket. Prior to sample thermal annealing the vacuum chamber was subjected to a verification procedure to assess cleanliness and base pressure. Standard space flight hardware procedures were followed throughout the tests. The maximum ramp rate of 0.2°C per minute allowed for a smooth and slow transition from ambient to test temperature.

The multilayer samples were initially heated to 50°C for 386 hours, upon which EUV and X-ray reflectance measurements at Columbia University confirmed no degradation. The annealing temperature was then raised to 75°C and the samples were held at 75°C for a thousand hours; a vacuum pressure of 1 x 10⁻⁷ mBar was achieved within 24 hours from the start of sample heating.

6. PROTON AND NEUTRON IRRADIATION

The main source of radiation will be solar energetic particles. These are discussed in the Solar Orbiter Environment Specification (7) with predicted values of the radiation doses. We carried out radiation tests in order to determine whether high-energy radiation could destroy the multilayers in any way. Irradiation tests were carried out in air at the Université Catholique de Louvain Cyclotron (CRC), Belgium. In our tests we could not reach the maximum energies of protons and neutrons achieved so we took an average, and a fluence predicted over the lifetime of the mission. For each

sample studied, only a portion of the surface was irradiated in order to compare individual damage effects on irradiated vs. non-irradiated zones. This was achieved using masking techniques, as described below.

During proton irradiation, the four multilayer samples were mounted in a copper sample holder, two by two. Using PTFE blocks and masks on the sample holder, only the centre part of the proton beam was used to radiate the multilayer samples ensuring a constant level of irradiation over all four multilayer sample halves (each multilayer sample was masked such that only half of it was subjected to the proton bombardment). Figure 5 illustrates this.

During neutron irradiation, the neutron beam used was much smaller in radius compared to the proton beam. The total area of the neutron beam was 2.5 cm^2 and was aimed at the group of four multilayer samples to only irradiate half their surface. The far corners of each sample were not radiated (see Figure 6).

After the radiation tests the samples were returned to Columbia University where the radiated and shielded area of each multilayer sample was characterised.

The proton radiation requirement from (4) is a fluence of 10^{11} protons/cm² at 30 MeV. The centre part of the beam was used where the flux was constant. We achieved the required fluence by irradiating the multilayer samples for 1000 seconds with a flux of approximately 10^8 protons/cm²/sec. The multilayer sample temperature was recorded during the test and showed only a random variation of 0.1°C from 24.5°C ambient as expected.

The neutron radiation requirement from (4) is a fluence of 10^6 neutrons/cm² at 45-50 MeV. The required flux was achieved by irradiating the multilayer samples with approximately 7810 neutrons/cm²/sec, with an energy of 45 MeV for 129 seconds. The holder's temperature was recorded during the test and shows only a random variation of 1 C from 25 C ambient.

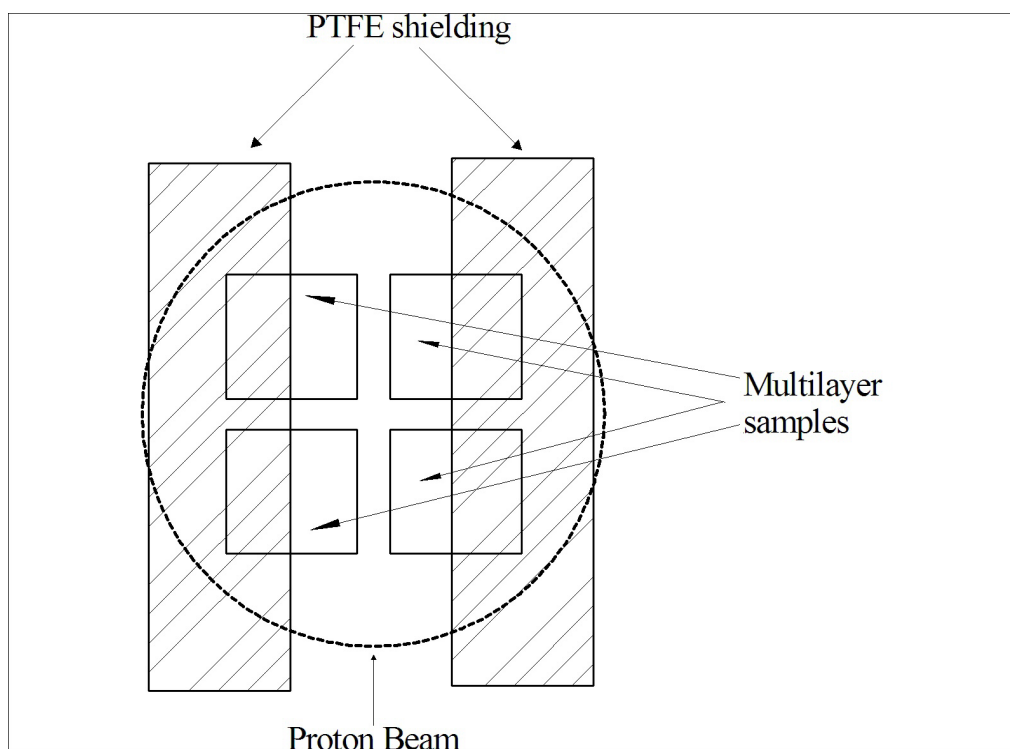

Figure 5: The figure shows the four samples with the shielding masking half of each sample and the contour of the (oversized) proton beam.

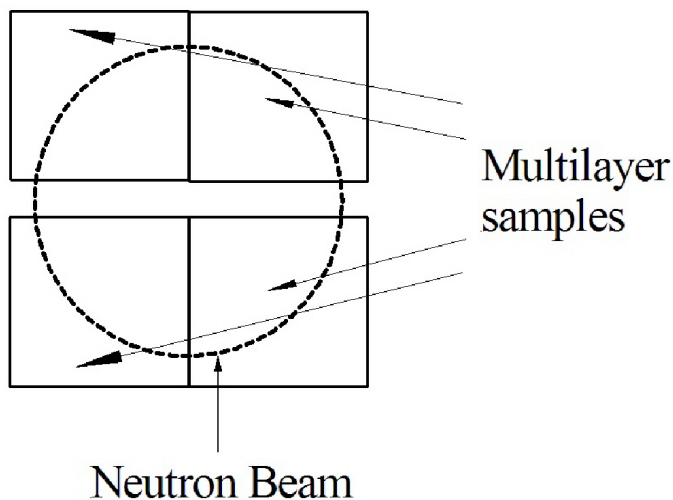

Figure 6: The figure shows the four multilayer samples radiated by the neutron beam.

7. RESULTS

Shown in Figs. 7 – 10 are the EUV and X-ray reflectance results, comparing the reference samples to the heated and irradiated samples for each of the four candidate multilayer samples investigated. For each multilayer system, all the measurements were made at about the same time, thereby removing from this comparison the small changes over time already identified resulting from oxidation of the coating top surface upon exposure to air, or to slight changes at the layer interfaces.

The EUV reflectance measurements shown here indicate no significant changes for any of the samples, to within the experimental uncertainty of the laser-plasma-based reflectometer. Similarly, the X-ray results reveal no significant structural changes as well.

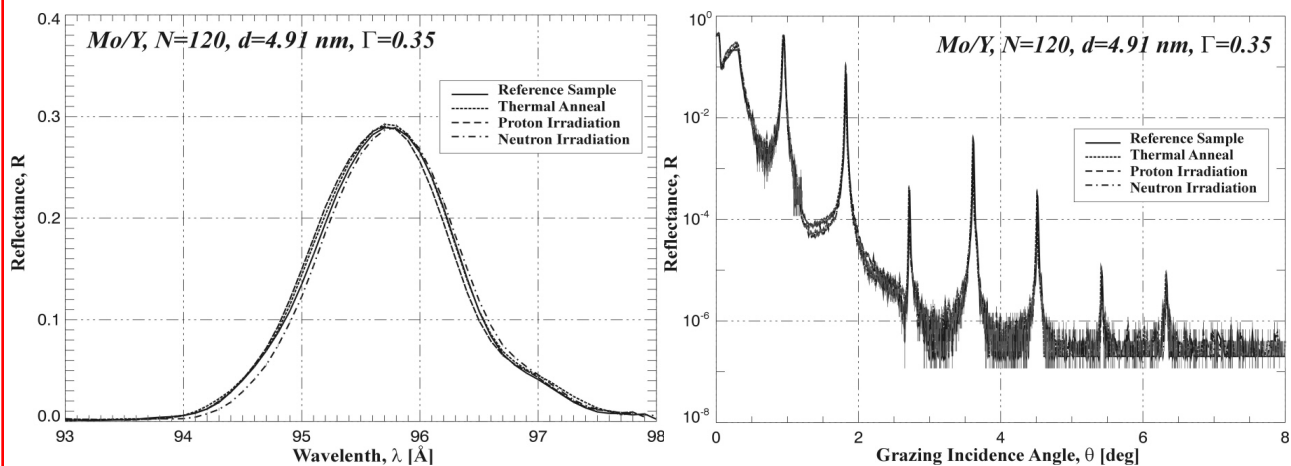

Figure 7 EUV and X-ray reflectance test on the Mo/Y multilayer sample reference, thermal annealing, proton and neutron test results superimposed.

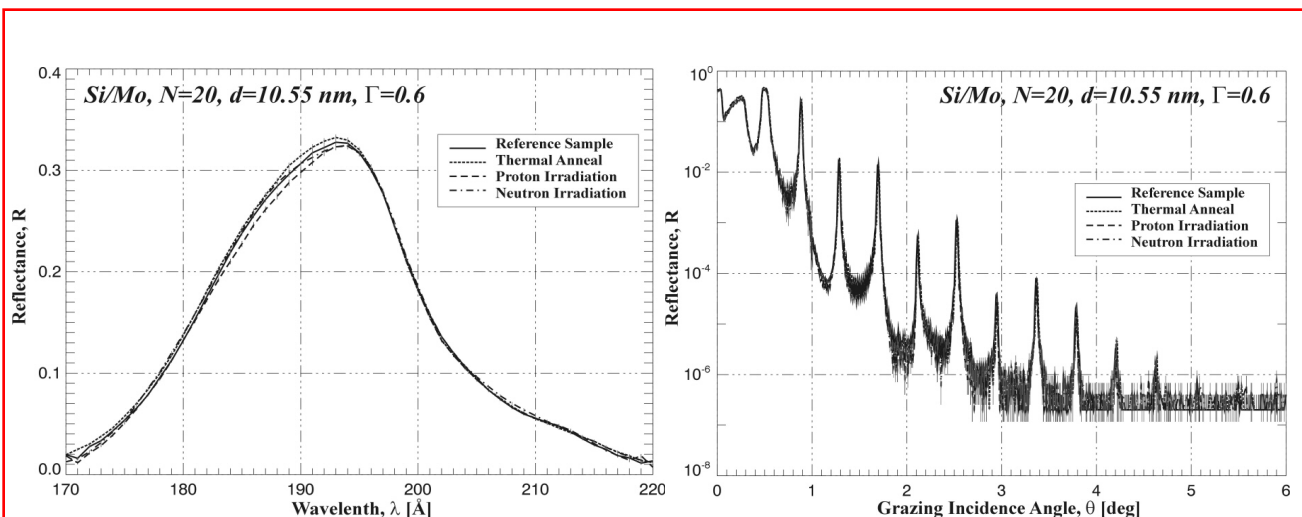

Figure 8 EUV and X-ray reflectance test on the Si/Mo multilayer sample reference, thermal annealing, proton and neutron test results superimposed.

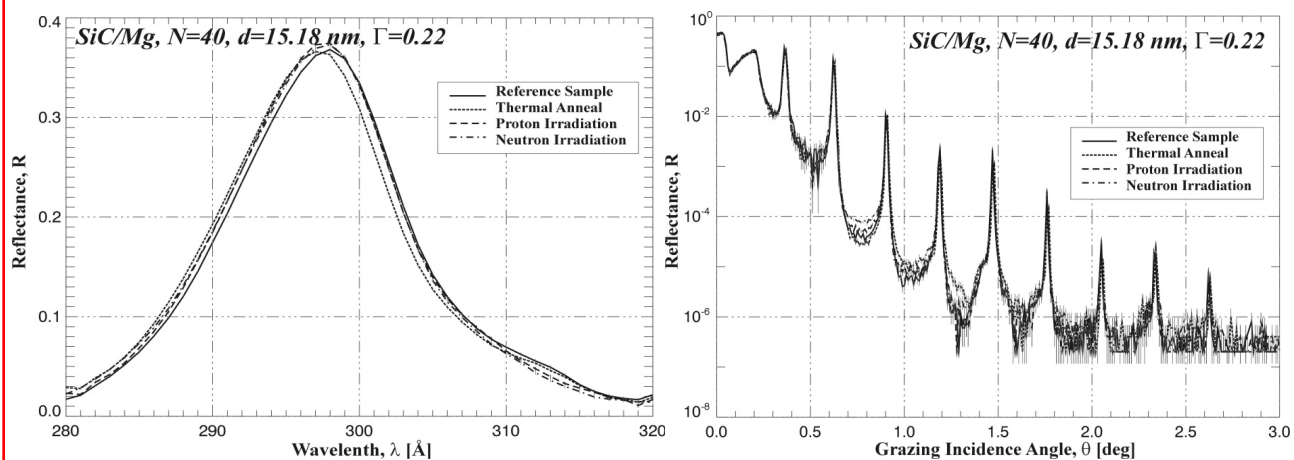

Figure 9 EUV and X-ray reflectance test on the SiC/Mg multilayer sample reference, thermal annealing, proton and neutron test results superimposed.

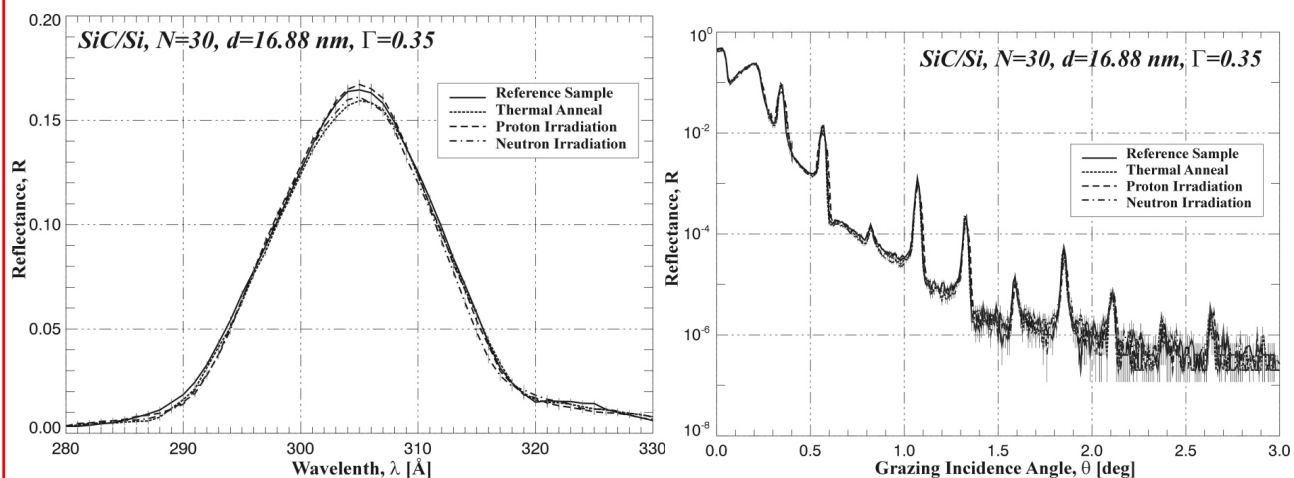

Figure 10 EUV and X-ray reflectance test on the SiC/Si multilayer sample reference, thermal annealing, proton and neutron test results superimposed.

8. CONCLUSIONS

We have investigated the effects of long-term heating, and energetic proton and neutron irradiation, on four candidate EUV multilayer coatings under consideration for use in extreme solar missions such as Solar Orbiter. Specifically we have exposed Mo/Y, Si/Mo, SiC/Si and SiC/Mg multilayers to 1000 h of heating at 75°C, and air irradiation to a 30 MeV protons (flux of $10^8/s/cm^2$ for 1000 s) and 45 MeV neutrons (flux of $7.8 \times 10^3/s/cm^2$ for 129 s). By comparing the annealed and irradiated samples with control samples stored in air, we find no significant changes in EUV performance, nor any microstructural changes identified by X-ray reflectometry, in any of the four multilayers systems investigated. These results suggest that all of the multilayers studied here should be well suited for use in solar missions with orbits close to the Sun.

ACKNOWLEDGEMENTS

We thank Guy Berger for his assistance during the radiation testing and PPARC for their funding.

REFERENCES

1. D. L. Windt and W. K. Waskiewicz, 'Multilayer facilities for EUV lithography', J. Vac. Sci. Technol. B, 12, 3826 - 3832 (1994)
2. J. F. Seely, C. M. Brown, D. L. Windt, S. Donguy, and B. Kjornrattanawanich, 'Normal-incidence efficiencies of multilayer-coated laminar gratings for the Extreme-Ultraviolet Imaging Spectrometer on the Solar-B mission', App. Op., 43, 1463 - 1471 (2004)
3. R. Soufli, D. L. Windt, J. C. Robinson, S. L. Baker, E. Spiller, A. L. Aquila, F. J. Dollar, E. M. Gullikson, J. F. Seely, B. Kjornrattanawanich, and L. Golub, 'Development and testing of EUV multilayer coatings for the Atmospheric Imaging Assembly instrument on the Solar Dynamics Observatory', Proc. SPIE, 5900 (2005) - i.e., these proceedings!
4. ESA Solar Orbiter payload definition document, SCI-A/2004/175/AO
5. L. Harra, C. Kankelborg, R. Thomas, J. Fox and B. Winter, 'An imager with added value for the Solar Orbiter mission', 35th COSPAR Scientific Assembly. Held 18 - 25 July 2004, in Paris, France., p.1120 (2004)
6. R.J. Thomas and C.C Kankelborg,, 'Optical Design of the MOSES Sounding Rocket Experiment', American Astronomical Society, 199th AAS Meeting, #88.07; Bulletin of the American Astronomical Society, Vol. 33, p.1434 (2001)
7. J. Sorensen, 'Solar Orbiter Environment Specification', TOS-EMA-03-034/JS, 2003.